

## 5-Phase Stepping Motor Drive IC for Universal Controller

# PMM8714PT

### Outline

"PMM8714PT" is a Bi-CMOS monolithic IC to be used for controlling 5-phase stepping motor.

This IC has been developed for the purpose to further simplify the usage of 5-phase stepping motor. When combined only with the switching elements or a power hybrid IC, this IC can configure a driver device for a 5-phase stepping motor.

### Characteristics

- Universal controller : Selection is possible from the following three different excitation modes.  
4EX/4-5EX/5EX
- Power voltage: :  $V_{CC}=4V\sim 16V$
- High output current: : 20mA min(source)
- High noise margin : Schmitt trigger circuit is integrated for the all input terminals
- two kinds of pulse input : double input system (CW, CCW input mode), single input system (CK,U/D input mode)
- Power-down functions : Makes all the output to "L" level.
- Reset functions : Shifts excitation status to the phase origin.
- Excitation mode preservation functions : Phase output does not change even when excitation mode is switched as follows: 4EX\_4-5EX\_5EX.
- Phase origin monitor : Outputs at the "H" level at the time of phase origin (the output in reset mode).
- Determination monitor for excitation status : Outputs monitor signal for the status of controller.
- Input pulse monitor : Outputs monitor signal for  $V_{CC}$  input pulse.

### Maximum Rating ( $T_a = 25^{\circ}\text{C}$ )

Item	Symbol	Rating	Unit
Power voltage	$V_{CC}$	-0.5~20	V
Output current $I_{OH}$	"H" level	-30	mA
	"L" level	2	
Output current $I_{OL}$	"H" level	-50	$\mu A$
	"L" level	2	mA
Input voltage	$V_{IN}$	-0.5~ $V_{CC}$	V
Input current	$I_{IN}$	$\pm 1$	mA
Tolerated loss	$P_D$	1000	mW
Operating temperature	$T_{opr}$	-20~85	$^{\circ}C$
Storage temperature	$T_{stg}$	-55~150	$^{\circ}C$

### Recommended Operating Conditions ( $T_a = -30$ to $85^{\circ}C$ )

Item	Symbol	Rating			Unit
		Min.	Standard	Max.	
Power voltage	$V_{CC}$	4	—	16	V
Output current $I_{OH}$	"H" level	—	—	-10	mA
	"L" level	—	—	1.6	
Output current $I_{OL}$	"H" level	—	—	-40	$\mu A$
	"L" level	—	—	1.6	mA
Input voltage	$V_{IN}$	0	—	$V_{CC}$	V
Clock frequency	—	0	—	250	kHz

## Dimensions (unit: mm)

Pin No.	Name	Function
1.	C <sub>U</sub>	Input pulse UP clock input
2.	C <sub>D</sub>	Input pulse DOWN clock input
3.	C <sub>K</sub>	Input pulse clock input
4.	U/D	Alters rotation direction
5.	E <sub>A</sub>	Input to switch excitation mode
6.	E <sub>B</sub>	Input to switch excitation mode
7.	E <sub>C</sub>	Input to switch excitation mode
8.	P <sub>D</sub>	Power down input
9.	Z <sub>O</sub>	Phase origin monitor output
10.	C <sub>O</sub>	Input pulse monitor output
11.	E <sub>M</sub>	Excitation monitor output
12.	GND	0V
13.	$\bar{R}$	Reset input
14.	$\phi \bar{E}$	$\phi \bar{E}$ output
15.	$\phi \bar{D}$	$\phi \bar{D}$ output
16.	$\phi \bar{C}$	$\phi \bar{C}$ output
17.	$\phi \bar{B}$	$\phi \bar{B}$ output
18.	$\phi \bar{A}$	$\phi \bar{A}$ output
19.	$\phi E$	$\phi E$ output
20.	$\phi D$	$\phi D$ output
21.	$\phi C$	$\phi C$ output
22.	$\phi B$	$\phi B$ output
23.	$\phi A$	$\phi A$ output
24.	V <sub>CC</sub>	4-16V

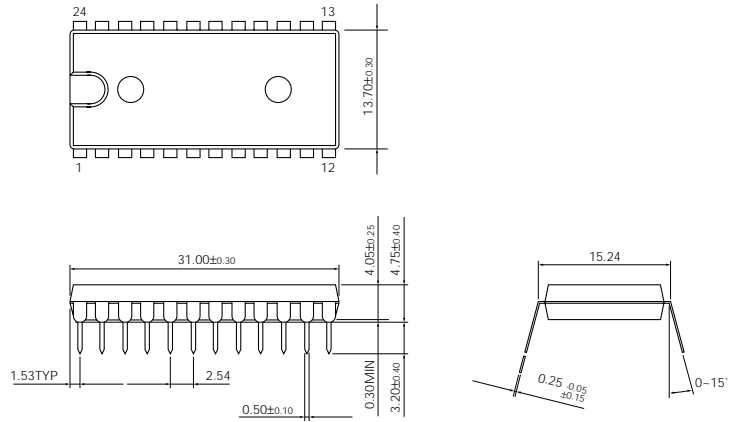

## Electrical characteristics

Direct Current Characteristics (Ta=25°C)

Item	Symbol	VCC [V]	Conditions	Standard Value			Unit
				Min.	Standard	Max.	
Output current $\phi A-\phi \bar{E}$	"H" level	5	$V_O = V_{CC}-2.0$	-20	—	—	mA
		10		-20	—	—	
	"L" level	5	$V_O = 0.3V$	1.6	—	—	
		10		1.6	—	—	
Output voltage C <sub>O</sub> ,E <sub>M</sub> ,Z <sub>O</sub>	"H" level	5	$I_O = -40\mu A$	3.6	—	—	V
		10		8.6	—	—	
	"L" level	5	$I_O = 1.6mA$	—	—	0.4	
		10		—	—	0.6	
Input voltage	"H" level	5	—————	3.0	2.5	—	V
		10		6.0	5.0	—	
	"L" level	5	—————	—	2.0	1.5	
		10		—	4.0	3.0	
Input voltage C <sub>U</sub> ,C <sub>D</sub> ,C <sub>K</sub> E <sub>A</sub> ,E <sub>B</sub> ,E <sub>C</sub>	"H" level	5	$V_{IN} = V_{CC}-0.5$	—	—	0.4	mA
		10		—	—	0.7	
	"L" level	5	$V_{IN} = 0V$	—	—	±10	
		10		—	—	±10	
Input voltage U/D,P <sub>D</sub> ,R	"H" level	5	$V_{IN} = V_{CC}-0.5$	—	—	-100	μA
		10		—	—	-100	
	"L" level	5	$V_{IN} = 0V$	—	—	-0.4	
		10		—	—	-0.7	
Static current consumption	I <sub>CC</sub>	5	All terminals open	—	—	25	mA
		10		—	—	35	

## Electrical characteristics

Switching Characteristics (Ta=25°C)

Item	Symbol	VCC [V]	Conditions	Standard Value			Unit
				Min.	Standard	Max.	
Max. clock frequency	f <sub>MAX</sub>	5	-----	250	300	—	kHz
		10		270	350	—	
Min. clock pulse width	t <sub>w</sub>	5	-----	—	300	500	ns
		10		—	300	500	
Min. reset pulse width	t <sub>wR</sub>	5	-----	—	200	500	ns
		10		—	200	500	
Delay time (ø output from clock input)	t <sub>PHL</sub>	5	-----	—	2500	3500	ns
	t <sub>PLH</sub>	10		—	2500	3500	
Delay time (Each monitoring from clock input)	t <sub>PHL</sub>	5	-----	—	3000	4000	ns
	t <sub>PLH</sub>	10		—	3000	4000	
Preset time	t <sub>SET</sub>	5	-----	4000	3000	—	ns
		10		4000	3000	—	
Holding time	t <sub>HOLD</sub>	5	-----	500	0	—	ns
		10		500	0	—	

Switching Characteristics

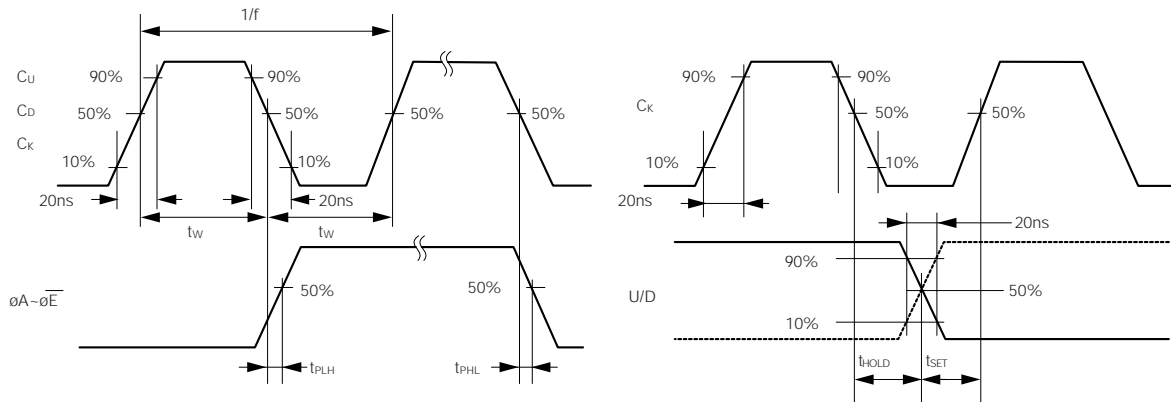

## Function table

Input mode and rotating direction

Input system	Input				Rotation direction
	C <sub>u</sub>	C <sub>d</sub>	C <sub>k</sub>	U/D	
Double input system (CW,CCW)		L	L	L	CW
	L		L	L	CCW
Single input system (CK,U/D)	L	L		H	CW
	L	L		L	CCW

Excitation mode

Energization system	Input				
	$\bar{R}$	$\bar{P}_d$	E <sub>A</sub>	E <sub>B</sub>	E <sub>C</sub>
4 EX	H	H	L	H	L
4-5EX	H	H	L	L	L
5 EX	H	H	H	L	L

# Energization sequence

4EX

Pulse Phase	0 (Reset)	1	2	3	4	5	6	7	8	9	10
$\phi A$	1	0	0	0	0	0	0	1	1	1	1
$\phi B$	1	1	0	0	0	0	0	0	1	1	1
$\phi C$	1	1	1	0	0	0	0	0	0	1	1
$\phi D$	1	1	1	1	0	0	0	0	0	0	1
$\phi E$	0	1	1	1	1	0	0	0	0	0	0
$\phi \bar{A}$	0	0	1	1	1	1	0	0	0	0	0
$\phi \bar{B}$	0	0	0	1	1	1	1	0	0	0	0
$\phi \bar{C}$	0	0	0	0	1	1	1	1	0	0	0
$\phi \bar{D}$	0	0	0	0	0	1	1	1	1	0	0
$\phi \bar{E}$	0	0	0	0	0	0	1	1	1	1	0
$Z_0$	1	0	0	0	0	0	0	0	0	0	1
$E_M$	0	0	0	0	0	0	0	0	0	0	0
UP	→										
DOWN	←										

5EX

Pulse Phase	0 (Reset)	1	2	3	4	5	6	7	8	9	10
$\phi A$	1	1	0	0	0	0	0	1	1	1	1
$\phi B$	1	1	1	0	0	0	0	0	1	1	1
$\phi C$	1	1	1	1	0	0	0	0	0	1	1
$\phi D$	1	1	1	1	1	0	0	0	0	0	1
$\phi E$	0	1	1	1	1	1	0	0	0	0	0
$\phi \bar{A}$	0	0	1	1	1	1	1	0	0	0	0
$\phi \bar{B}$	0	0	0	1	1	1	1	1	0	0	0
$\phi \bar{C}$	0	0	0	0	1	1	1	1	1	0	0
$\phi \bar{D}$	0	0	0	0	0	1	1	1	1	1	0
$\phi \bar{E}$	1	0	0	0	0	0	1	1	1	1	1
$Z_0$	1	0	0	0	0	0	0	0	0	0	1
$E_M$	1	1	1	1	1	1	1	1	1	1	1
UP	→										
DOWN	←										

4-5EX

Pulse Phase	0 (Reset)	1	2	3	4	5	6	7	8	9	10	11	12	13	14	15	16	17	18	19	20
$\phi A$	1	1	0	0	0	0	0	0	0	0	0	0	0	1	1	1	1	1	1	1	1
$\phi B$	1	1	1	1	0	0	0	0	0	0	0	0	0	0	0	1	1	1	1	1	1
$\phi C$	1	1	1	1	1	1	0	0	0	0	0	0	0	0	0	0	0	1	1	1	1
$\phi D$	1	1	1	1	1	1	1	1	0	0	0	0	0	0	0	0	0	0	0	1	1
$\phi E$	0	1	1	1	1	1	1	1	1	1	0	0	0	0	0	0	0	0	0	0	0
$\phi \bar{A}$	0	0	0	1	1	1	1	1	1	1	1	1	0	0	0	0	0	0	0	0	0
$\phi \bar{B}$	0	0	0	0	0	1	1	1	1	1	1	1	1	0	0	0	0	0	0	0	0
$\phi \bar{C}$	0	0	0	0	0	0	0	1	1	1	1	1	1	1	1	0	0	0	0	0	0
$\phi \bar{D}$	0	0	0	0	0	0	0	0	0	1	1	1	1	1	1	1	1	1	0	0	0
$\phi \bar{E}$	0	0	0	0	0	0	0	0	0	0	1	1	1	1	1	1	1	1	1	1	0
$Z_0$	1	0	0	0	0	0	0	0	0	0	0	0	0	0	0	0	0	0	0	0	1
$E_M$	0	1	0	1	0	1	0	1	0	1	0	1	0	1	0	1	0	1	0	1	0
UP	→																				
DOWN	←																				

# Input pulse monitor

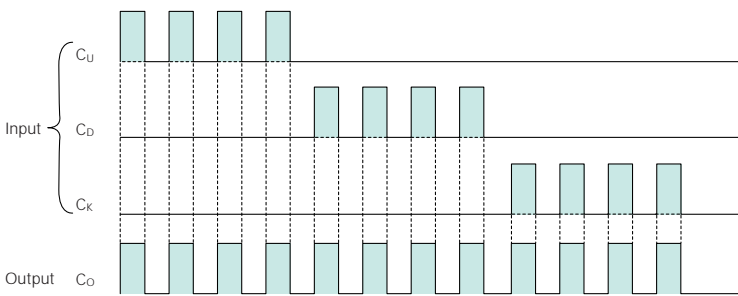

## Example application circuit (full step/half step)

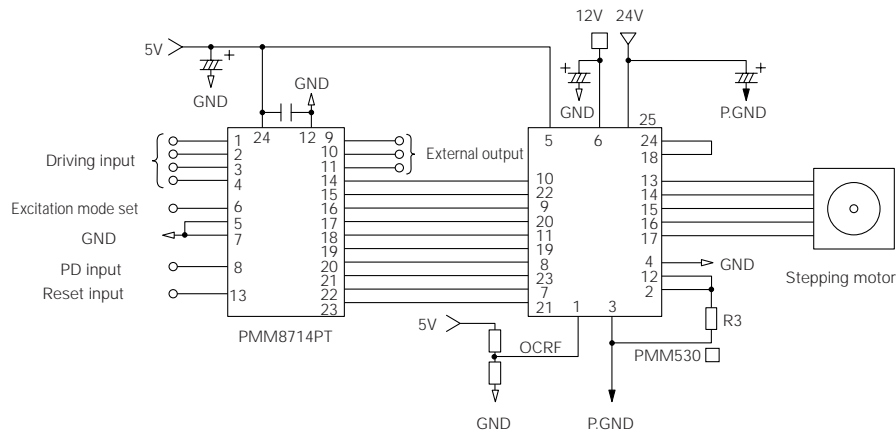

### Excitation mode set

Pin No.	Terminal symbol	Input level	Motor operation
6	EB	H	Full step
		L	Half step

- When VCC is not stable, such as immediately after the power is on, normal initial reset can not always be performed. In order to perform firm reset, hold R terminal (13pin) at the "L" level until Vcc becomes stable.

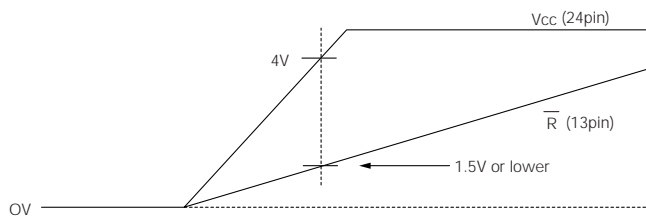

- Refer to Page 343 for the specifications of power hybrid IC:PMM530 □.
- Refer to Operation Manual of PMM8714PT for other applications.